

- ASSEMBLY GUIDE -

# SHELF LIBRARY AND SINGLE SHELF

Steel

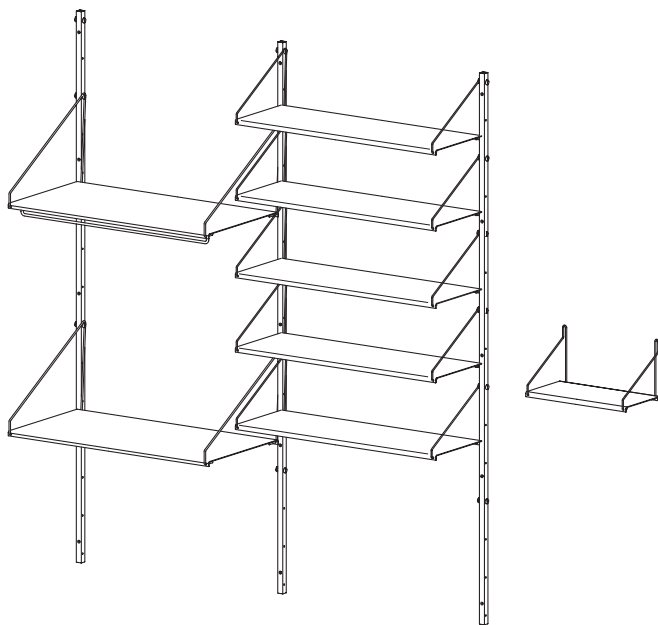

## FRAMA

# INDEX

3 Rail .....

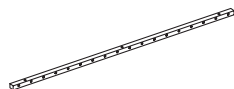

7 Shelf .....

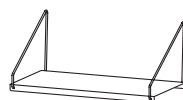

11 Single shelf .....

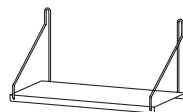

15 Hanger shelf .....

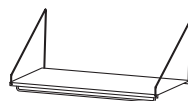

21 Cabinet .....

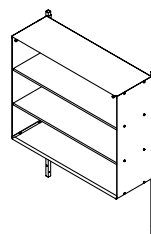

# RAIL

- PARTS -



**A** Rail



**B** Screw  
x4 for 1084 rail  
x5 for 1852 rail

1.

Place the first rail (A) on the desired position on the wall and put the screw (B) into the wall through the top hole. Depends on the wall type, pre-drilling and wall plug (not included) maybe required.

Use the the top hole as an anchor point and level the rail straight then mark the screw hole with a pencil or a sharp tool on the wall.

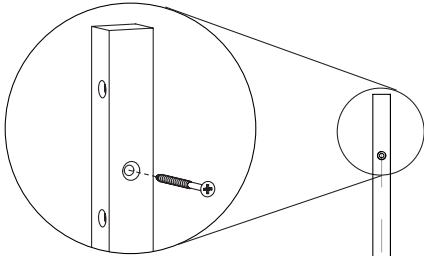

Anchor point

The logo text should be on the bottom side

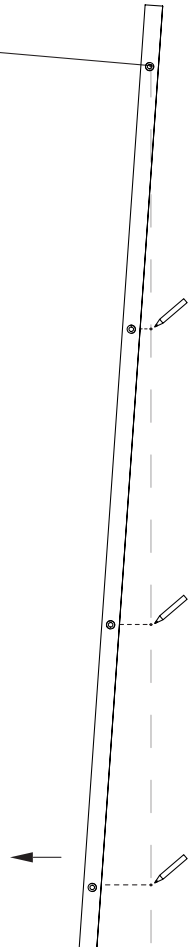
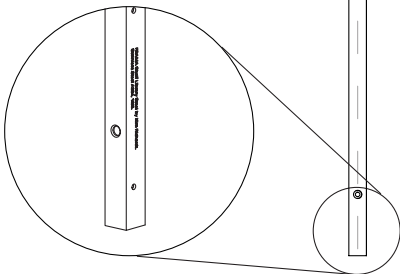

2.

Finish mounting the first rail by putting the screws (B) into the marked position.  
Measure the distances for the second rail (A), then mount the second rail by repeating the same process on page 4.

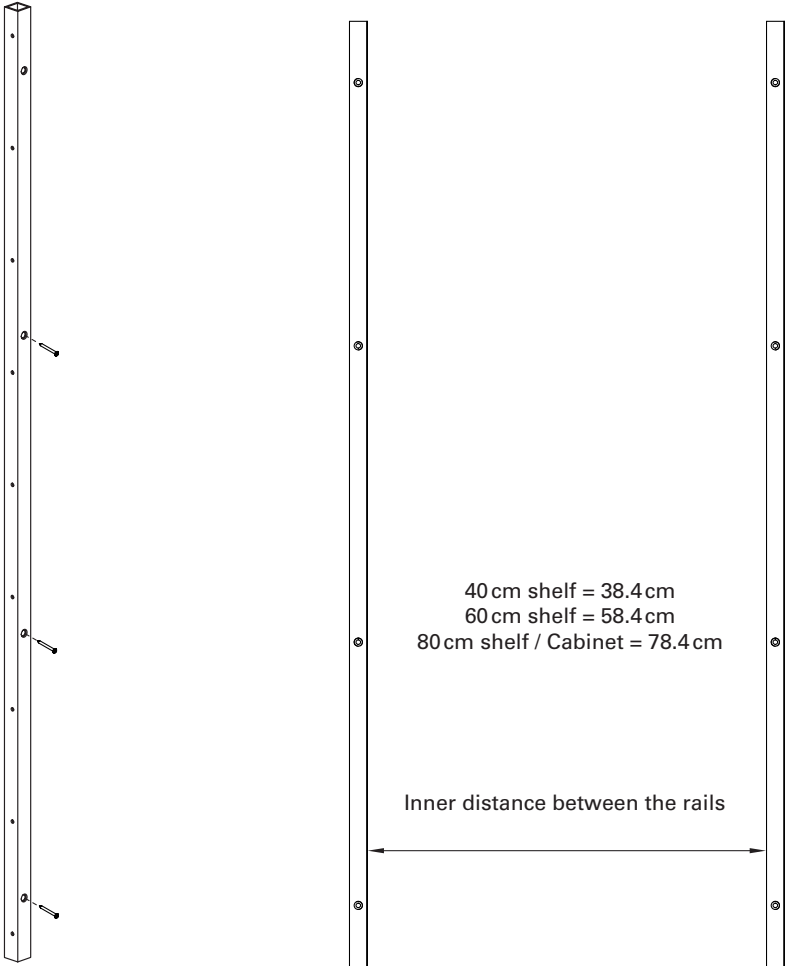

3.

To extend the system, repeat the same process on page 4 and 5.

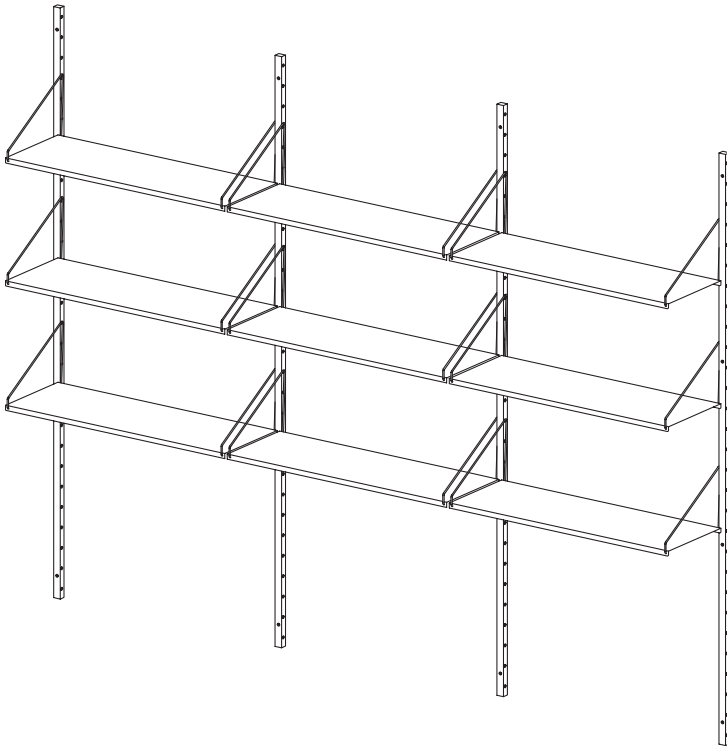

# SHELF

- PARTS -



Ⓐ Shelf x1

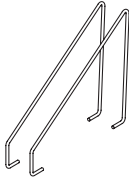

Ⓑ Bracket x2

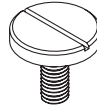

Ⓒ Bolt x4

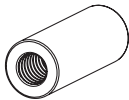

Ⓓ Threaded insert x2

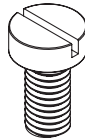

Ⓔ Spacing bolt x1

Only Ⓐ, Ⓑ, Ⓒ are required for this assembly.

1.

Start by inserting bracket ends (B) into the holes on the shelf (A).

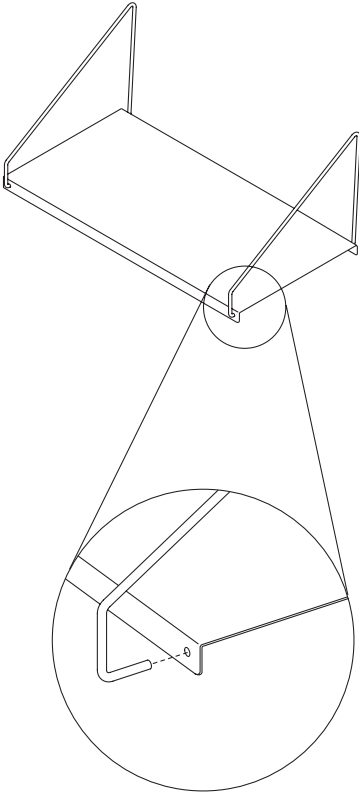

Front

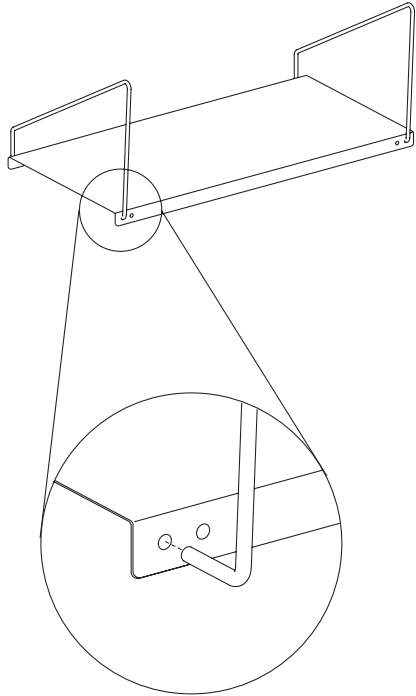

Back



2.

Place the shelf at a desired position in the rail, secure the bracket (B) to the rail by fastening the bolts (C) to the threaded hole in the rail.

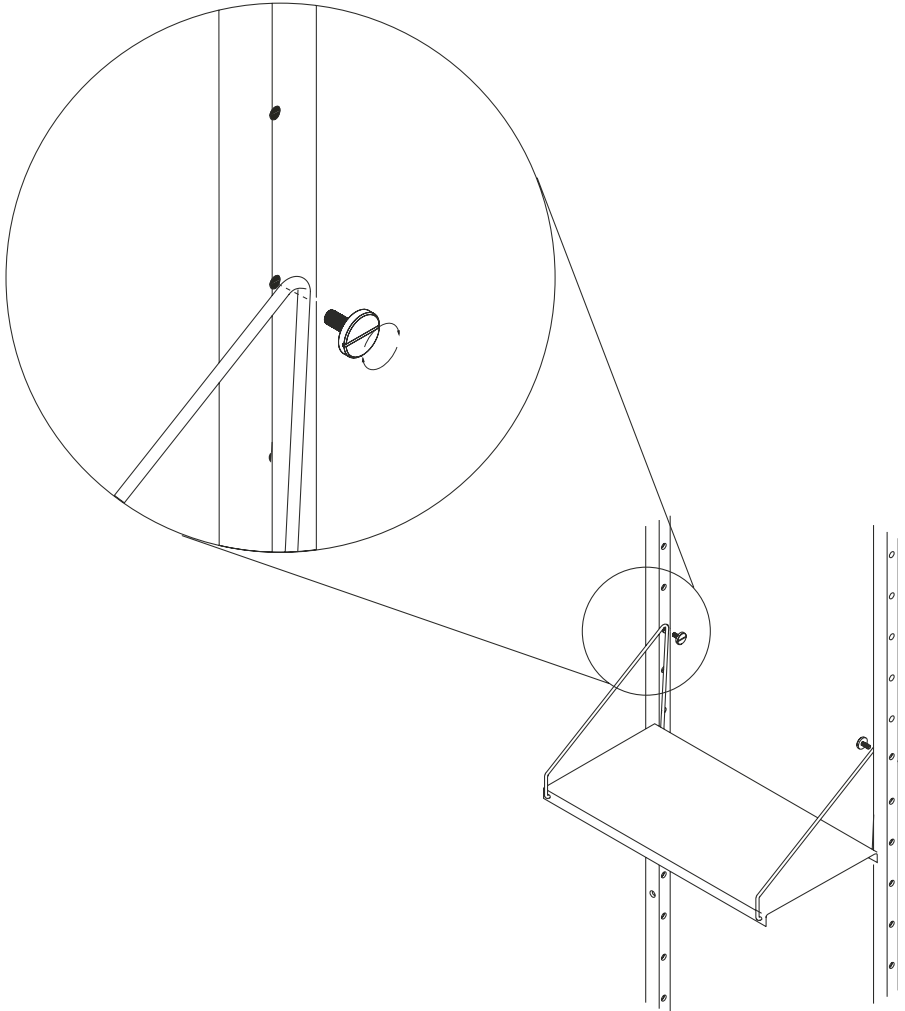

3.

Note that the back side of the shelf should be placed against the rail not to the wall.

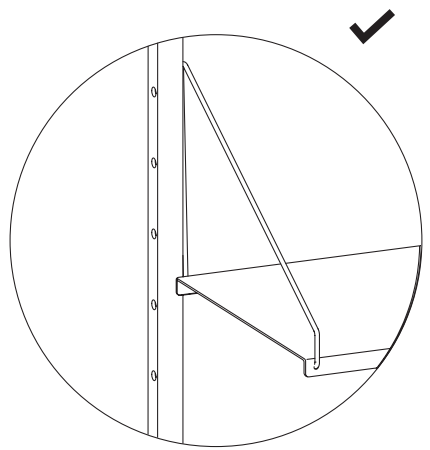
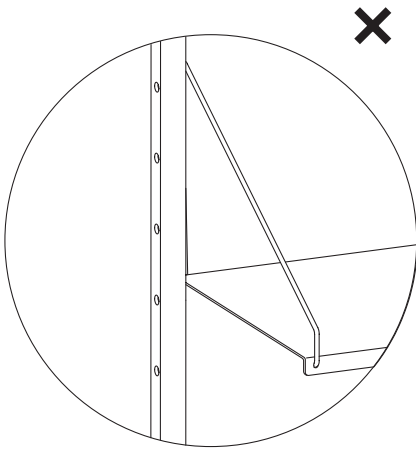

# SINGLE SHELF

- PARTS -



Ⓐ Shelf x1

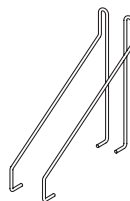

Ⓑ Bracket x2

1.

Start by inserting bracket ends (B) into the holes on the shelf (A).

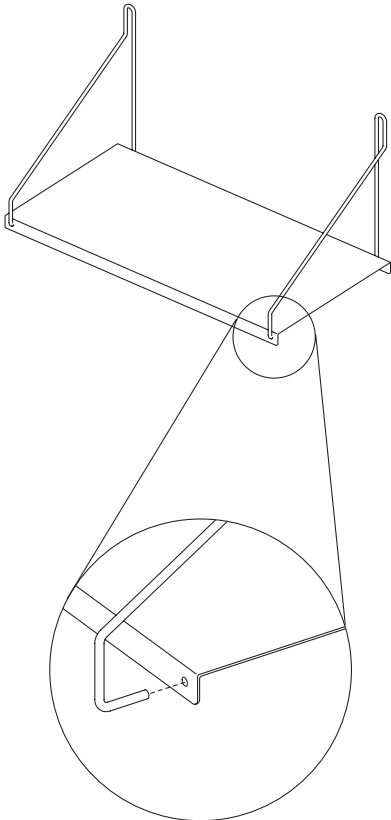

Front

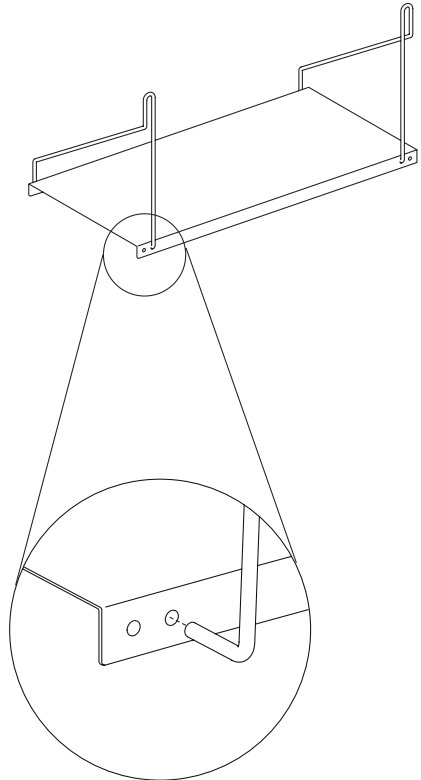

Back

2.

Make sure that the brackets are placed correct side.  
Place the complete shelf against the wall, level it straight then mark screw holes  
with a pencil or a sharp tool on the wall.



Front

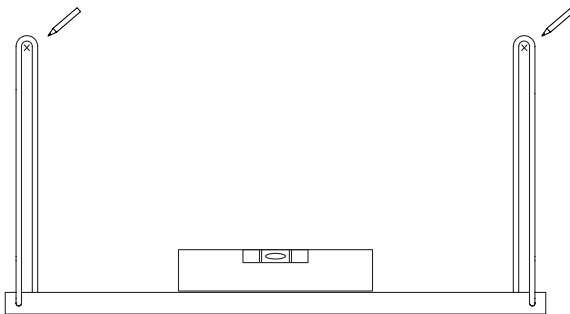

3.

Put screws into the marked position on the wall, then hang the bracket on. Depends on the wall type, pre-drilling and wall plug (not included) maybe required.

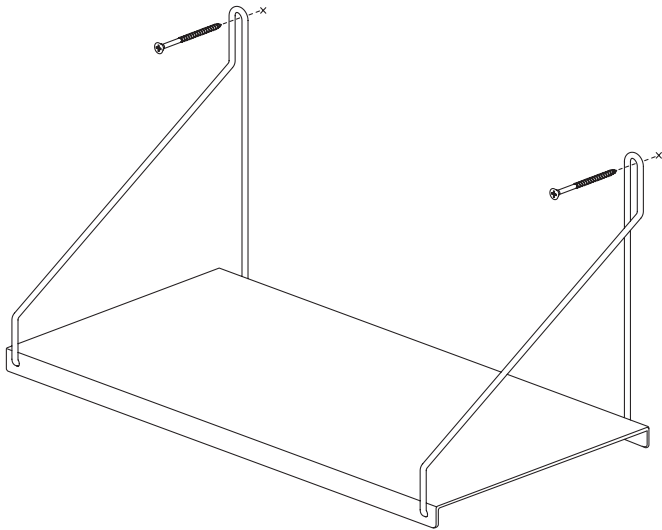

# HANGER SHELF

- PARTS -



(A) Shelf x1



(B) Hanger x1

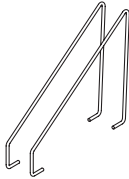

(C) Bracket x2

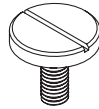

(D) Bolt x4

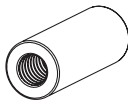

(E) Threaded  
insert x2

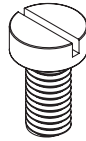

(F) Hanger / Spacing  
bolt x3

Only (A), (B), (C), (D), (F) are required for this assembly.

1.

Start by screwing the hanger bolts (F) into the hanger (B) through the shelf (A).

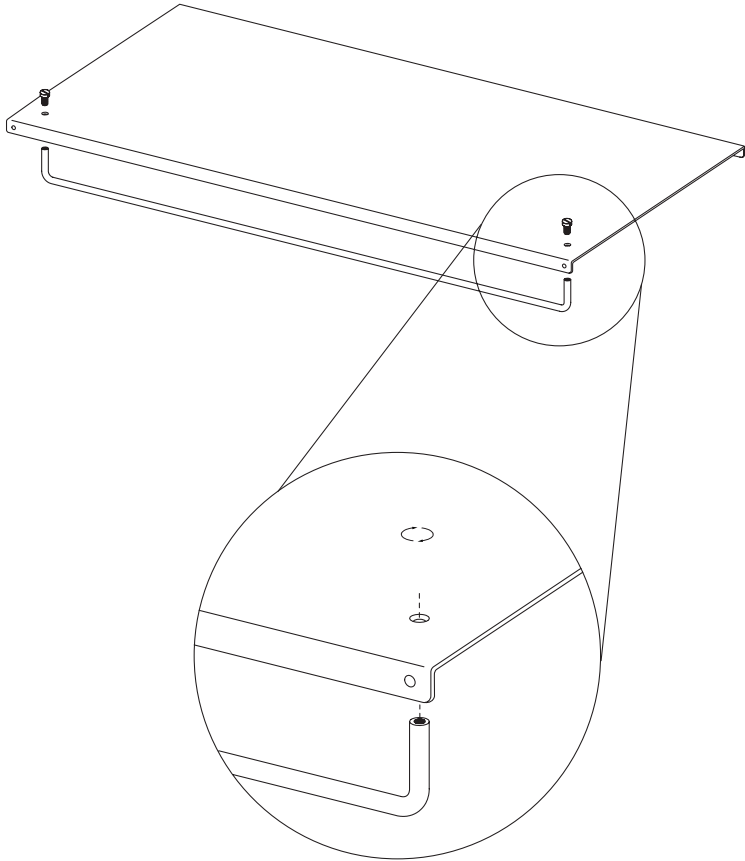



2.

Insert bracket ends ③ into the holes on the shelf ①.

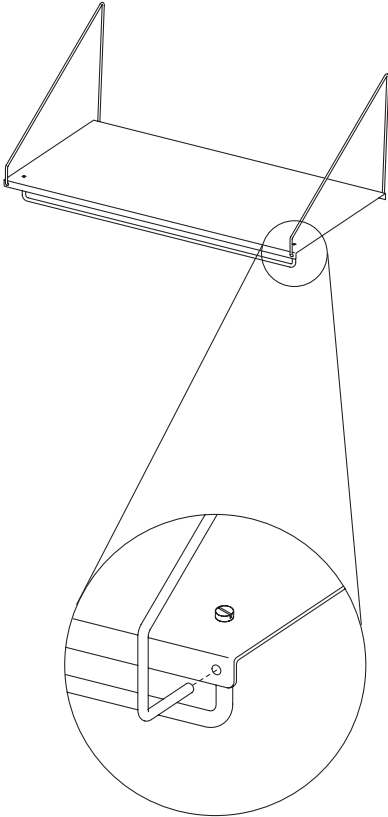

Front

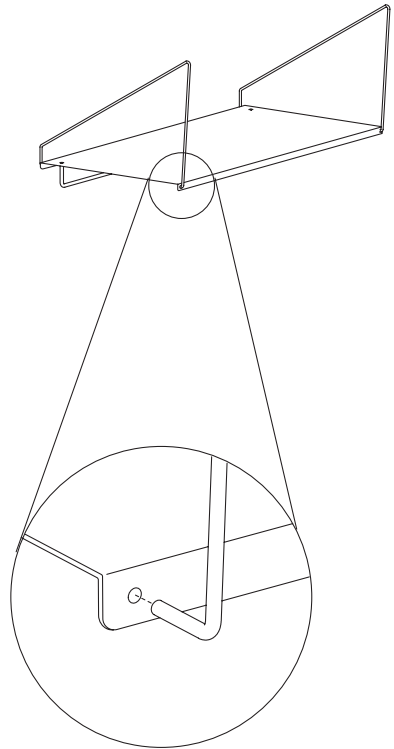

Back

3.

Place the shelf at a desired position in the rail, secure the bracket **Ⓒ** to the rail by fastening the bolts **Ⓓ** to the threaded hole in the rail.

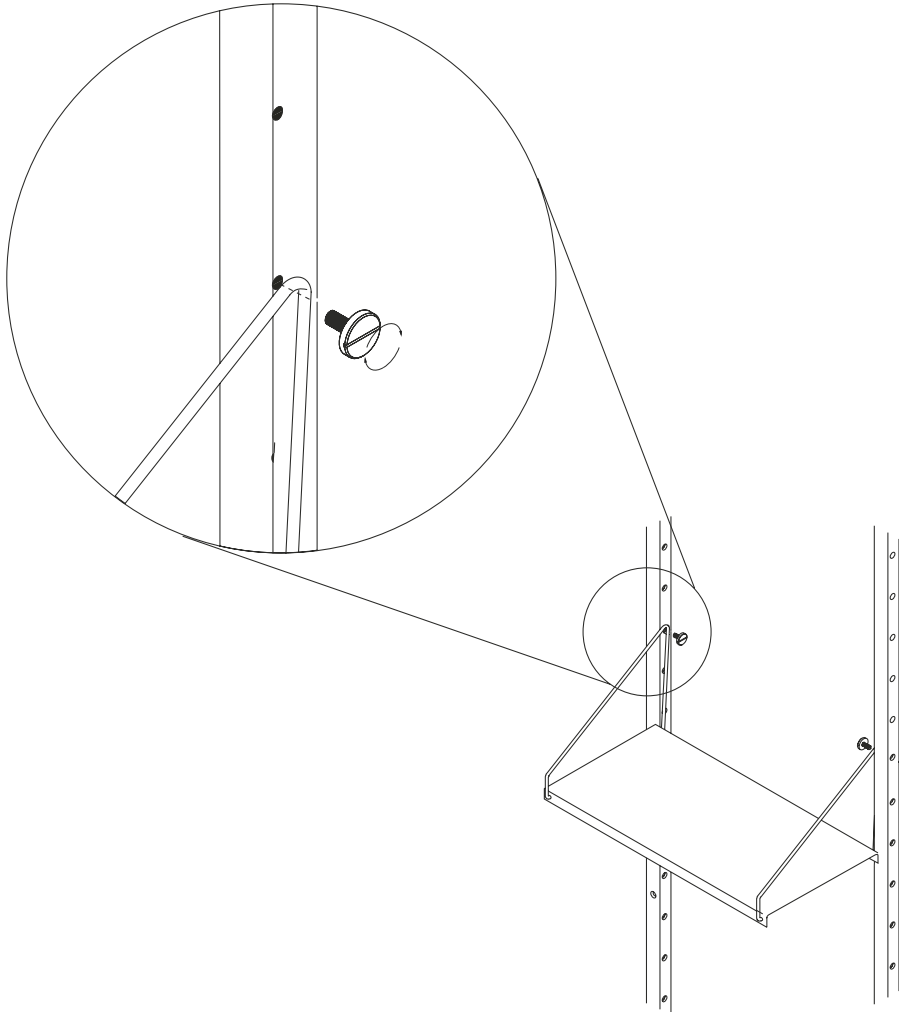

4.

Note that the back side of the shelf should be placed against the rail not to the wall.

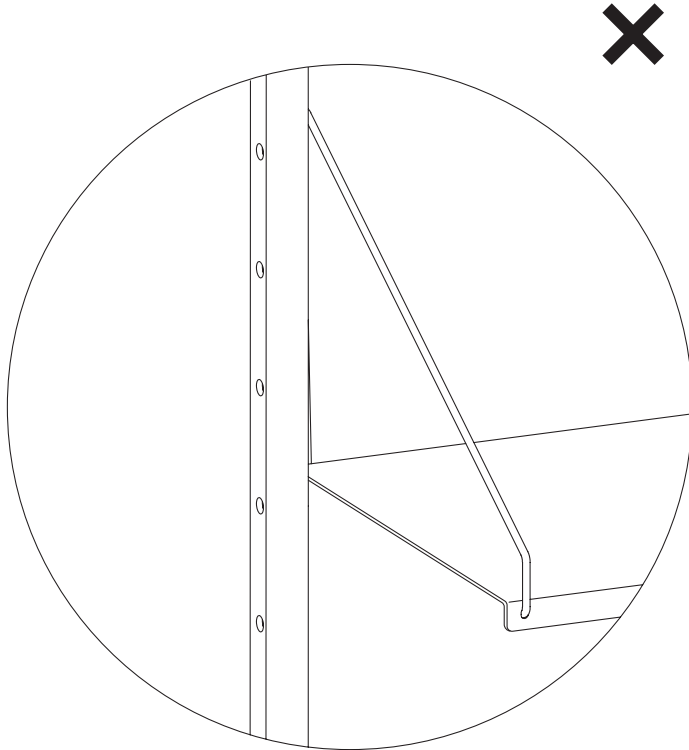

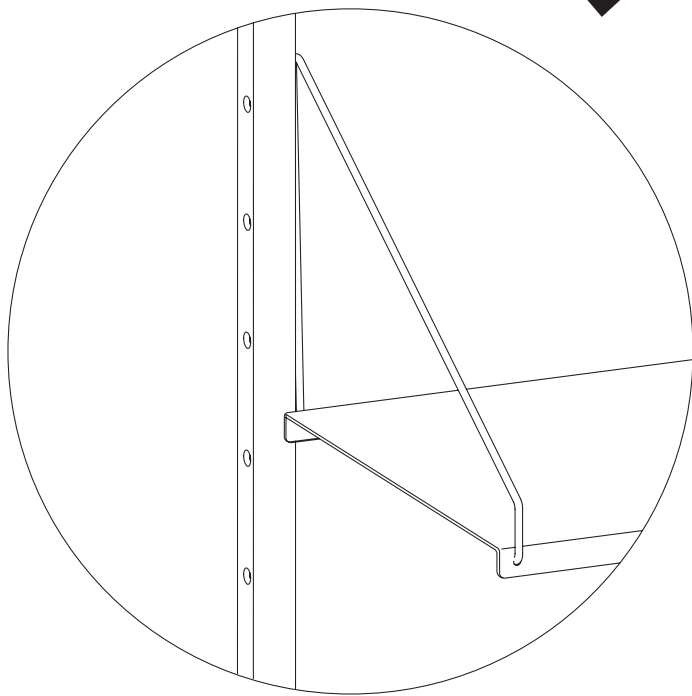

# SHELF LIBRARY CABINET

- PARTS -



(A) Back screw x12



(B) Spacer x8



(C) Screw x16



(D) Bolt x4



(E) Nut x28



(F) Mounting hook x2



(G) Flat Wrench



(H) Allen Key

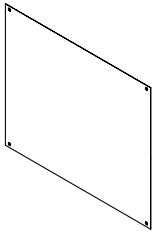

(I) Canvas Curtain

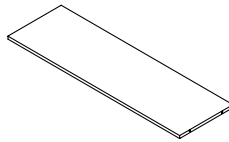

(J) Shelf x2

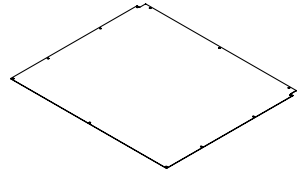

(K) Back Panel x1

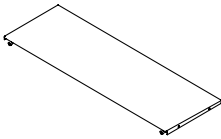

(L) Top Part

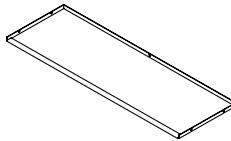

(M) Bottom Part

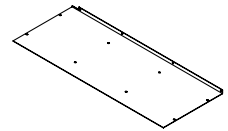

(N) Side Panel x2

1.

Fasten the side panels (N) to the back panel (K) using the back screws (A), spacers (B) and nuts (E). Make sure to start with the 2 center holes of the back panel (K).

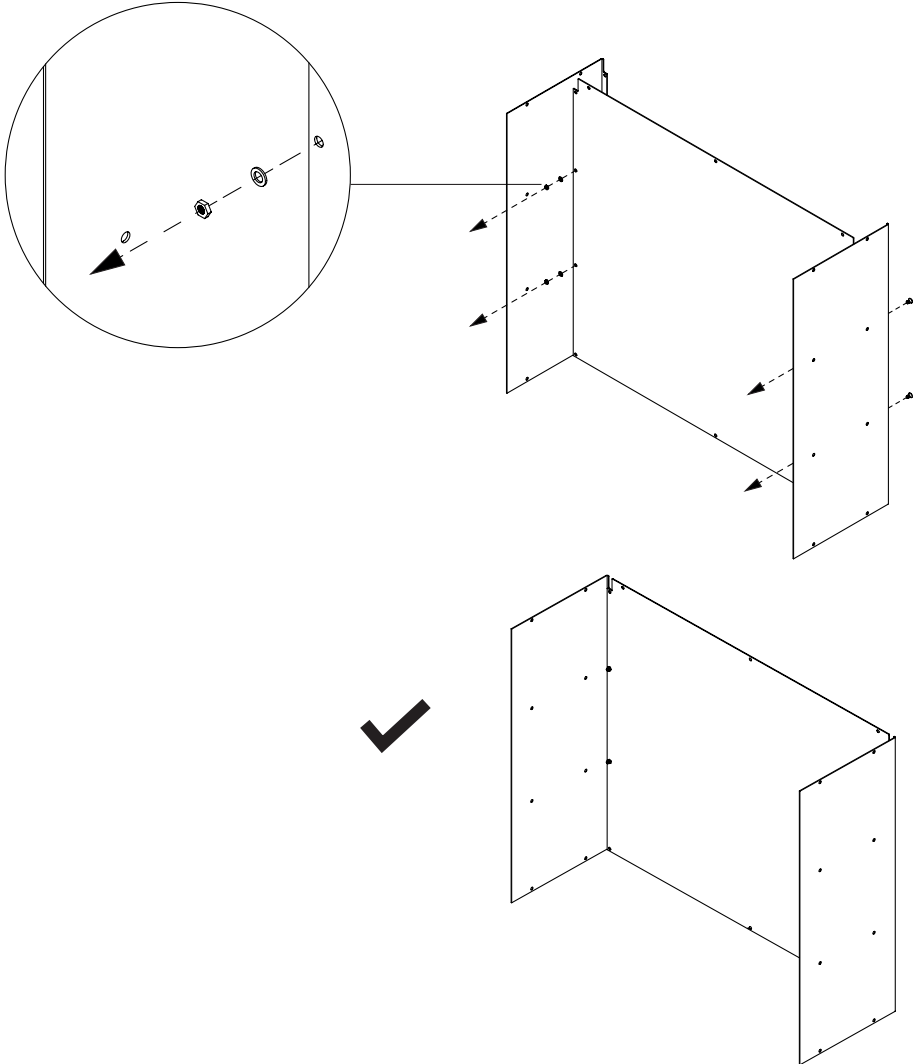

NOTES : Do not completely fasten the nuts before the end.  
Make sure to be two persons for assembly

2.

Once screwed, place it flat on the back.

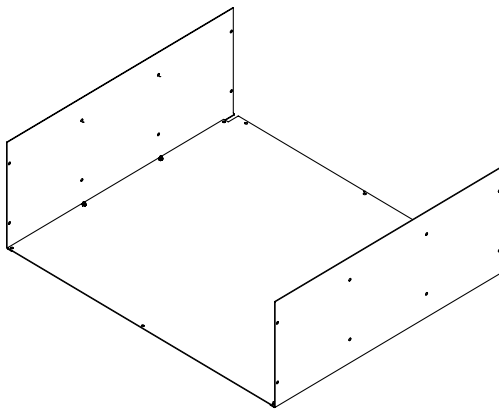
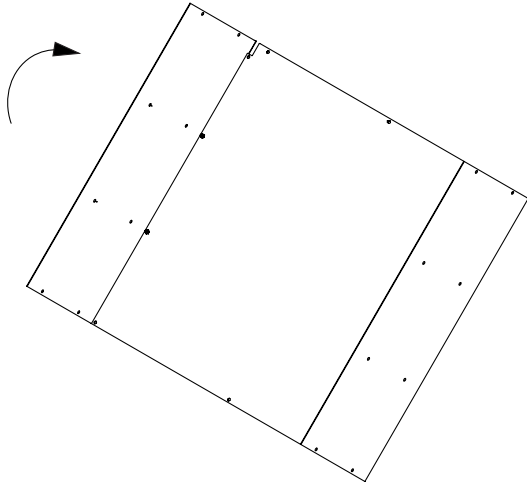

3.

Next insert the screws (C), nuts (E) and spacers (B) between top part (L) and bottom part (M) to the side panels (N)

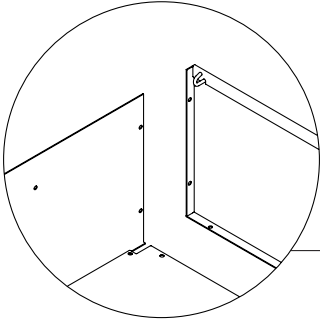

NOTE : Make sure to place the top part with hooks where holes on the back piece are.

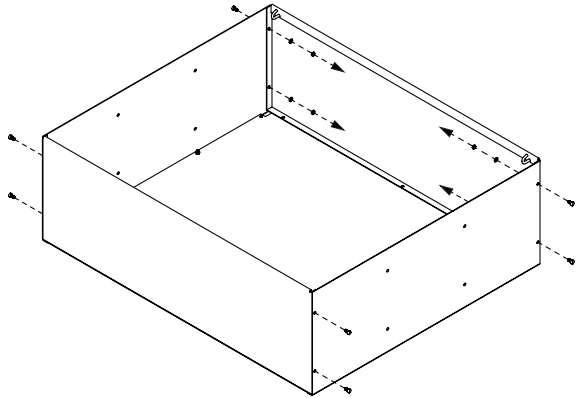
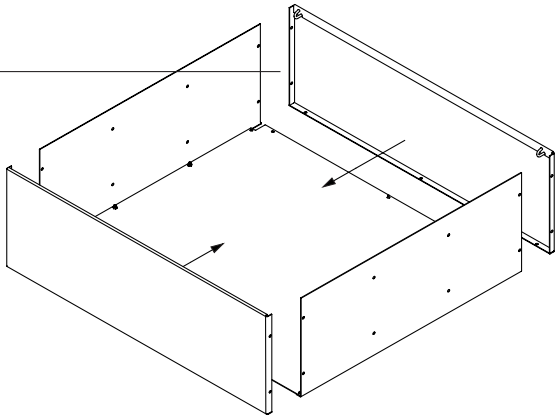

NOTE : Do not completely fasten the nuts before the end.



4.

Then place the shelves (J) inside the cabinet by screwing them with screws (C) nuts (E), and spacers (B) to the side panels (N).

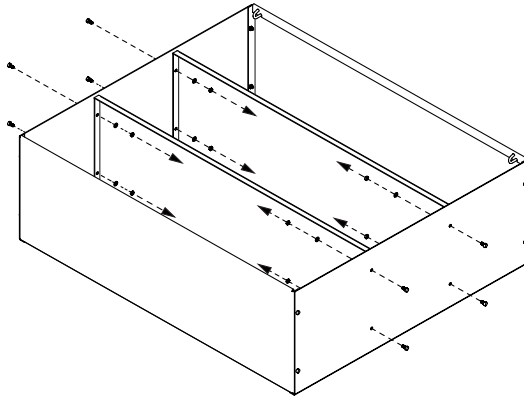
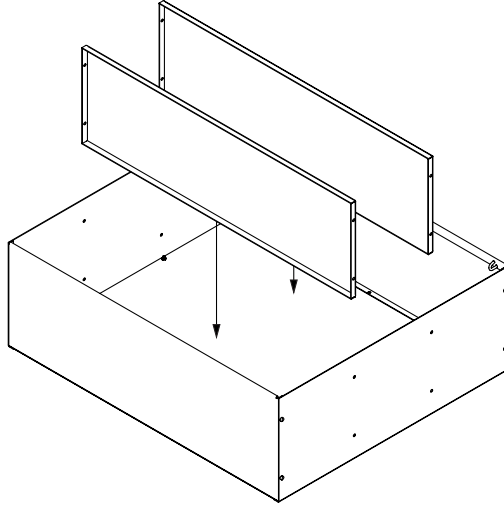

NOTE : Do not completely fasten the nuts before the end.

5.

Then rotate the cabinet on the bottom part (K).

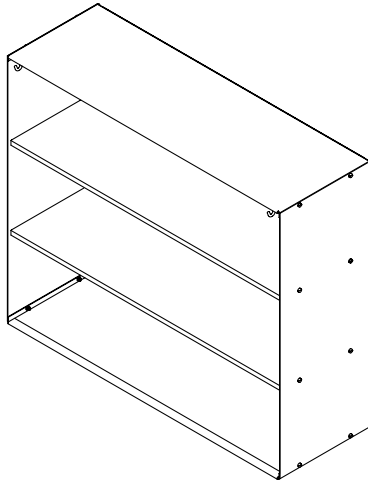
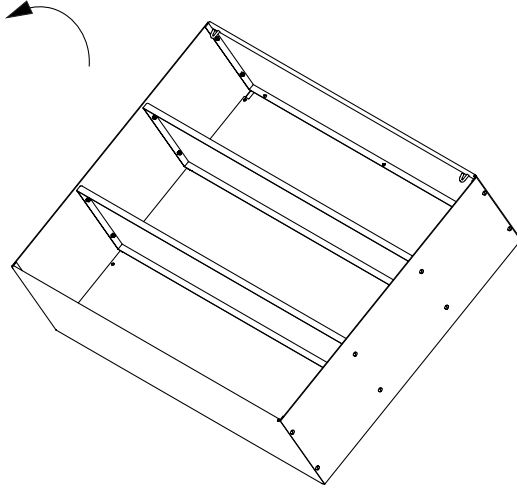

6.

Insert the back screws (A), nuts (E) and spacers (B) at the back of the cabinet.

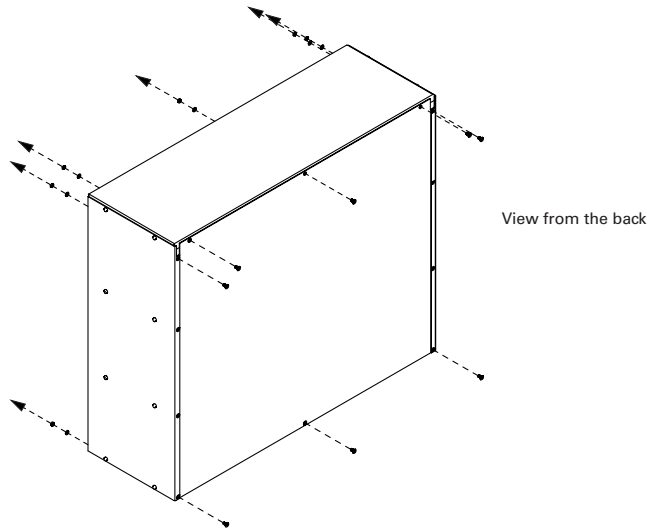
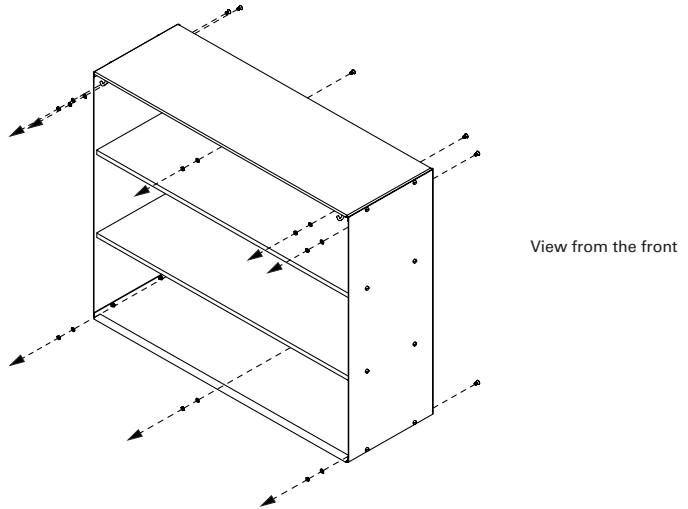

NOTE : Do not completely fasten the nuts before the end.

7.

You can now completely tighten all the nuts.

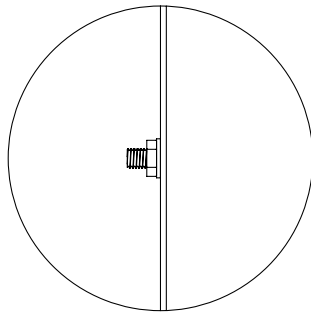
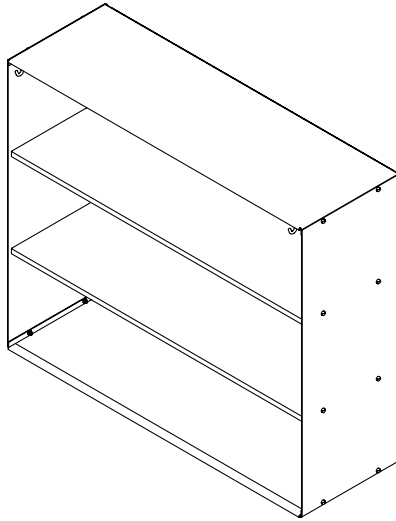

8.

Fasten the mounting hooks (F) to the rails using the bolts (D), then place the cabinet on it.

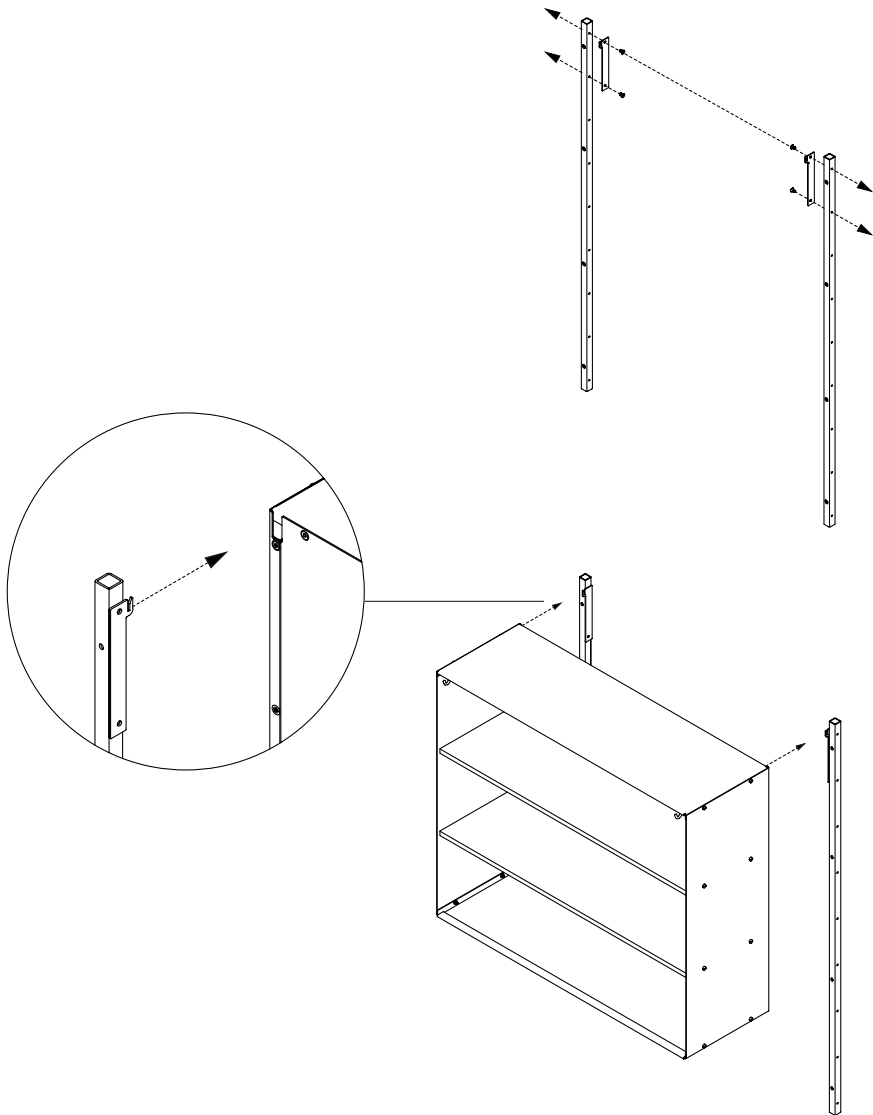

9.

Put the canvas curtain ① on the cabinet by placing the holes in the hooks.

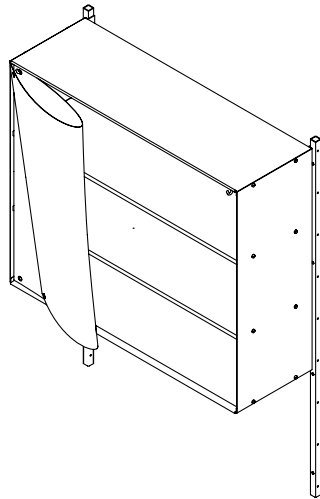
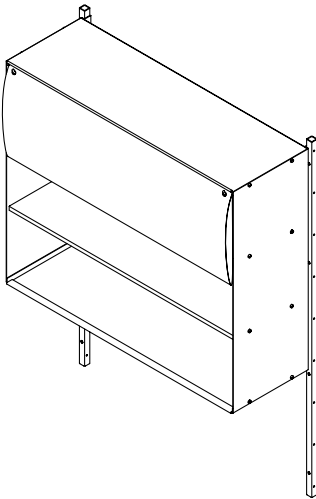
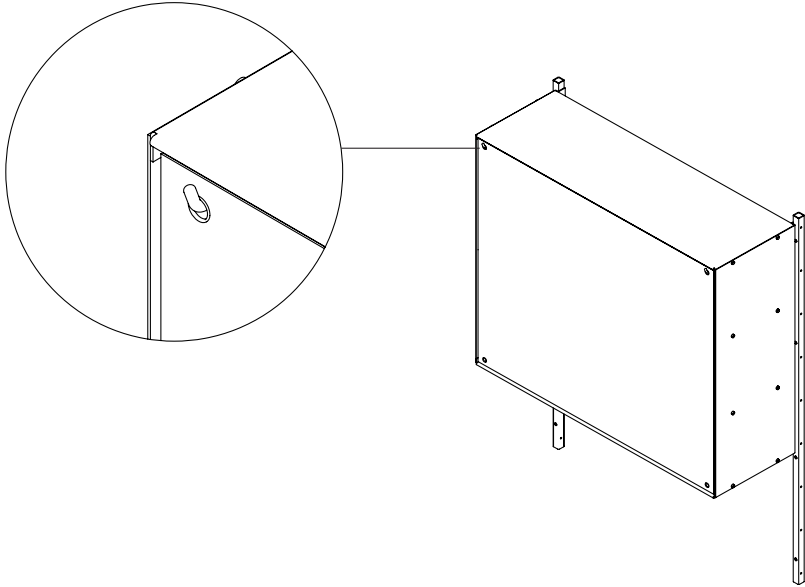

NOTE : Different configurations with the curvas curtain are possible

- Care & Maintenance Guide -

In order to preserve your new FRAMA pieces for years to come, we've produced a guide on the materials we use and how to best care for them. Following these instructions will help to maintain the appearance and quality of your items after repeated use and cleaning.

For material care and maintenance instructions, scan the QR code using your mobile device.



Access the guide on your desktop at  
**[framaph.com/pages/material-care-guide](https://framaph.com/pages/material-care-guide)**

FRAMA  
Fredericiagade 57, 1310  
Copenhagen K  
+45 3140 6030 [framacph.com](http://framacph.com)

**FRAMA**